

INSTALLATION AND OPERATING INSTRUCTIONS

WATERMARK

Watermark Electronic Module

SMART IRRIGATION CONTROL

The WATERMARK ELECTRONIC MODULE (WEM), with its pair of sensors, can be used to control:

- An individual valve (one WEM per valve)
- A group of valves watering areas of similar water demand (a Hydrozone) (one WEM per Hydrozone)
- All the valves on a controller (one WEM per controller)

The WEM can be installed indoors or outdoors, at the controller or at the valve.



WATERMARK SENSORS

The WATERMARK Soil Moisture Sensors are installed in an active root system area representative of that plant material which is being used as the control point for the individual valve or the Hydrozone area. If used to control an entire controller, select the area of greatest water demand. In selecting the site factors such as sprinkler distribution, topography, appearance of the turf or plant material and the amount of sun exposure should be considered. It would be preferable to locate the sensor in a drier area, avoiding low spots which may be on the wetter side due to runoff and drainage. Wires from the sensors are run back to the location where the WEM is mounted.

INSTALLING WATERMARK SENSORS

WATERMARKS are installed beneath the ground with two sensors at each location in the active root system of the turf or plant being monitored. Depth of placement varies with the rooting depth of the plant material being monitored.

Typical Installation Depths –

Shallow Rooted Turf	2" to 5" deep (in root system)
Deep Rooted Turf	6" to 8" deep (in root system)
Shrubs/Ground Cover	8" to 14" deep (in root system)
Trees	16" to 24" deep (in root system)

Step 1 — Soak WATERMARK sensors in water before installation. Always install a “wet” sensor.



Step 2 — For root systems that are less than 12" deep, sensors are installed 4" to 6" apart at each location at the same depth (see Typical Installation Depths). For root systems deeper than 12" (deep rooted shrubs or trees), sensors are installed at various depths. This gives an “average” reading, over the entire root profile, of the two sensors combined to activate or eliminate irrigation as needed.

Step 3 — Install a splice box (Ametek #182001/2 Econo Box or equal) within 2-3 feet of the sensor location and cut a trench from the splice box to the sensor location to bury the sensor wire.



0° - 45°

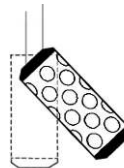

NOTE: The sensor wires can be run in conduit if desired. The top of the sensor will socket inside 1/2" class 315 PVC pipe, and can be solvent welded with ABS to PVC cement.

Step 4 — At the end of the trench, excavate a hole to the depth required for the sensors to be installed. Install the two sensors by pressing them partly into the soil within the plant's root area at the depths in this hole. A piece of 1/2" PVC pipe (class 315) can be used as an insertion tool to push the sensor in, being careful not to pinch the wires. Be sure the sensors are installed in the active root system of the turf, shrubs or trees. Sensors should be installed vertically or to a 45° downward angle into the soil. For deeper placement, a vertical borehole can be made with a piece of pipe with the sensor inserted to the bottom of the hole. Sensors **MUST** be firmly packed in the soil.

Step 5 — Backfill the sensors firmly to ensure a snug fit and run the sensor wires to the splice box. Backfill the sensor wire trench.

Step 6 — Separate the two conductors for each sensor and strip insulation for making the waterproof splices. Splice one wire from each sensor together, running them in series. Then splice each remaining wire to the wires running back to the site where the WEM is located. Refer to Sensor Wire Sizing Chart.

Sensor wire sizing

Up to 1000'	#18 AWG-UF Valve Wire
1000' to 2000'	#16 AWG-UF Valve Wire
2000' to 3000'	#14 AWG-UF Valve Wire



PLEASE NOTE: Sensors must be installed in the area irrigated by the last valve to run in each valve “group”. Resequence valves to accomplish this as necessary. Keep a record in the controller enclosure of which valves are in each group, and which valves water the sensors.

INSTALLING THE WATERMARK ELECTRONIC MODULE (WEM)

Step 7 — Typically the WEM is mounted on the wall, or in the control enclosure, near the irrigation controller (when used to control Hydrozones or the entire controller). If controlling an individual valve, the WEM is best mounted near the valve it is to control and in the area irrigated by that valve. Take care to ensure the module does not become submerged in a flooded valve box. Mounting the WEM to the underside of the lid of the valve box or the splice box usually works well. Run wires from the valve(s) being controlled, or the controller, to the WEM and make waterproof connections as follows (see wiring diagrams):

For individual valve control:

- WEM black to valve station wire .
from controller + solenoid hot.
- WEM white to common.
- WEM red to solenoid common.
- WEM greens to sensors.

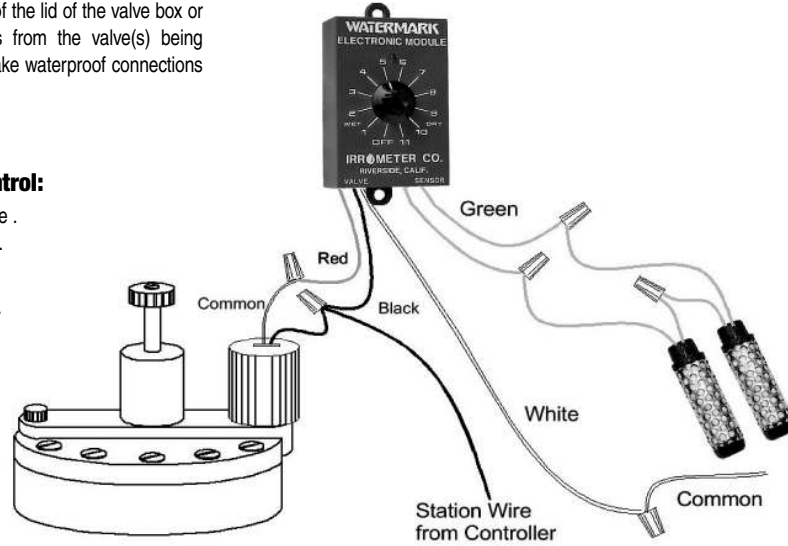

Controller

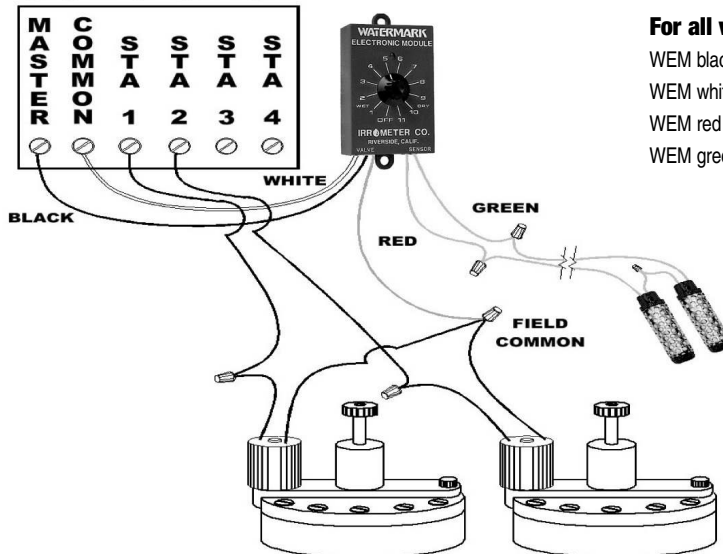

For all valve control:

- WEM black to master valve.
- WEM white to common.
- WEM red to field common.
- WEM greens to sensors.

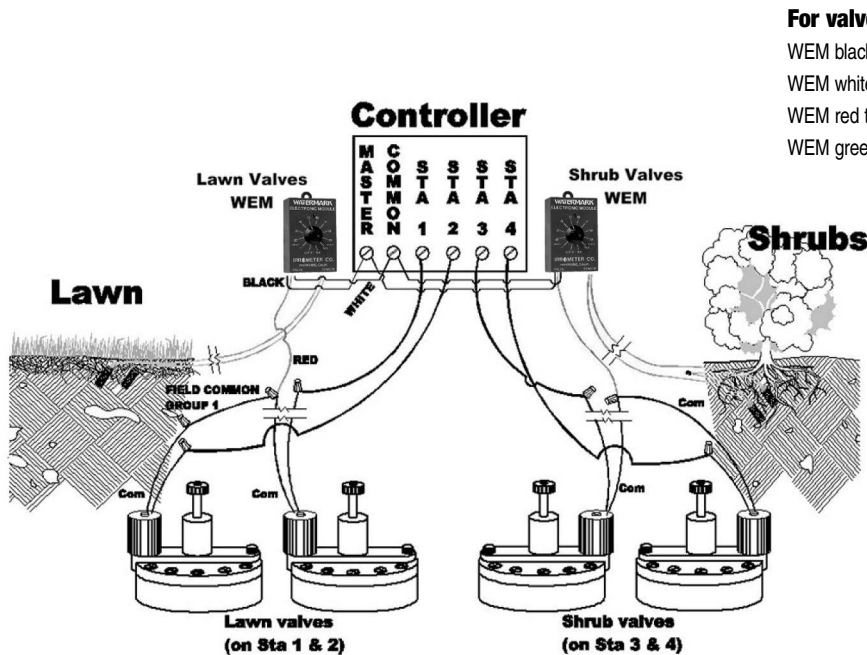

For valve group control:

- WEM black to master valve.
- WEM white to common.
- WEM red to valve group field common.
- WEM greens to sensors.

PROGRAMMING YOUR IRRIGATION CONTROLLER

Soil moisture setting

Each "irrigation need" group can be set for differing soil moisture levels. The WEM is adjustable from 10 to 120 centibars and has an OFF position to allow for overriding the sensors. The adjustment dial gives you from very wet (position #1) to very dry (position #11):

Positions #1 to #4 (approximately 10 centibars to 25 centibars): This is the normal range for most water sensitive turf or plant material.

Positions #5 to #8 (approximately 35 centibars to 70 centibars): This is the intermediate to drier soil moisture and is useful for most shrubs and ground cover.

Positions #9 to #11 (approximately 85 centibars to 120 centibars): This is the very dry end of the soil moisture range and should be used with caution. Some deep-rooted, drought tolerant, plant material may be able to tolerate this level of dryness.

Keep in mind that your Soil Moisture Sensors only serve to override your irrigation controller/time clock to prevent excessive or unnecessary irrigation. The irrigation controller is still "in control" and determines "when" irrigation can occur and "how long" a given valve can run. Thus, the key to successful use of this entire system depends on properly programming your irrigation controller. The correct programming procedure is as follows:

1. Allow the controller to come on as often as possible (except maybe the night before, or morning of, the mowing day). This means the controller is frequently "asking" the moisture sensors if irrigation is needed. It will operate ONLY when the sensors say it is necessary.

2. Set the valve cycle timer (duration/run time) for short cycles. This prevents the runoff you often see with longer cycles. The soil can absorb the water only so fast, and long cycles usually don't permit all the water to penetrate the soil where it is needed.
3. With the short cycles, you'll need to have several repeat cycles, or start times, each day. You may want to seek the advice of a professional irrigation consultant to help you set up a program of this type to meet peak consumptive use based on your specific system and plant material. Since this program can be used year round (except in freezing climates) with your moisture sensor control, you will eliminate the need for seasonal program adjustments. The sensors will automatically adjust the irrigation to whatever is needed, regardless of the weather.
4. Monitor your system and plant material to fine tune your moisture settings for proper balance and correct plant response. You can fine tune by:
 - A. Adjusting the moisture setting for a wetter or dryer control.
 - B. Changing the programmed cycle duration to prevent excessive runoff.
 - C. Changing the repeat cycles, or start times, to increase or decrease total irrigation "potential" to meet the peak consumptive use of the turf or plants.

Once you have established a balanced program, further adjustments become less necessary. All you need to do is monitor the results, thus eliminating the constant programming of the Controller for seasonal needs.

A free software program is available to assist you in creating the optimum schedule for your landscape. If you visit our website at <http://www.irrometer.com/download.htm#WP>, you can download a program called **WaterPerfect**. When prompted, use the word "conserve" without the quotation marks, for both the user name and password. The program requires Microsoft® Excel®. If you perform an irrigation audit on your landscape, you will have all the data necessary to input into the program, which will then generate a recommended schedule to be programmed into the controller.

INDICATOR LIGHT

Each WATERMARK Electronic Module (WEM) comes with an indicator light to make the unit simple to use and easy to understand. When the irrigation controller is powering a valve being controlled by the WEM, and the soil moisture conditions are at or drier than the setting you have selected on the WEM, then the light will come on, indicating irrigation is allowed. When the irrigation controller is powering a valve being controlled by the WEM, and the soil moisture conditions are wetter than the setting you have selected on the WEM, then the light will not come on, indicating irrigation is not needed and has not been allowed.

WEM OVERRIDE

There may be times when the WEM needs to be bypassed to allow the controller to operate in manual mode, for system maintenance, etc. There are two ways to bypass the WATERMARK Electronic Module. The first can be done at the WEM by turning the Moisture Control Dial to the "OFF" position. This closes the WEM switch and allows the valve(s) connected to the WEM to operate as desired.

The second way to override the WEM is with the addition of a Bypass Circuit, which is wired to a toggle switch at the irrigation controller. This is desirable on multiple WEM systems because the system user can bypass all WEMs at once. This Bypass Circuit requires a second common wire from the controller to all valve/WEM locations. It is spliced into the Red wire of the WEM and the valve solenoid. At the controller, this Bypass Circuit is connected to the main system common through a toggle switch installed on a controller panel. By closing the toggle switch, all sensors are bypassed (see WEM Bypass Circuit wiring diagram below).

OPERATING/FINE TUNING YOUR SYSTEM

With your Soil Moisture Sensors installed and wired, you are now ready to begin using them to control your irrigation system. For newly landscaped areas, it is advisable to temporarily bypass the sensors. This allows you to continue operating your irrigation controller as needed to establish a good root system for the first 60-90 days. Once this has been completed, and the root system has been established, you can begin to use and fine tune the Watermark soil moisture control system.

TESTING YOUR SYSTEM

1. Set Moisture Control Dial to OFF position. All valves should operate on a manual controller/time clock sequence.
2. Set Moisture Control Dial to DRY position. Sensors will override valve (prevent operation) when soil is wet.
3. Set Moisture Control Dial in the WET range. When soil has been allowed to dry sufficiently, sensors will allow valves to operate on a manual controller/time clock sequence.
4. Verify soil water status in sensor area with soil probe.

WARRANTY: The IRROMETER COMPANY warrants its products against defective workmanship or materials under normal use for one year from date of purchase. Defective parts will be replaced at no charge for either labor or parts if returned to the manufacturer during the warranty period. The seller's or manufacturer's only obligation shall be to replace the defective part and neither seller nor manufacturer shall be liable for any injury, loss or damage, direct or consequential, arising out of the use of or inability to use the product. This warranty does not protect against abuse, shipping damage, neglect, tampering or vandalism, freezing or other damage whether intentionally or inadvertently caused by the user.

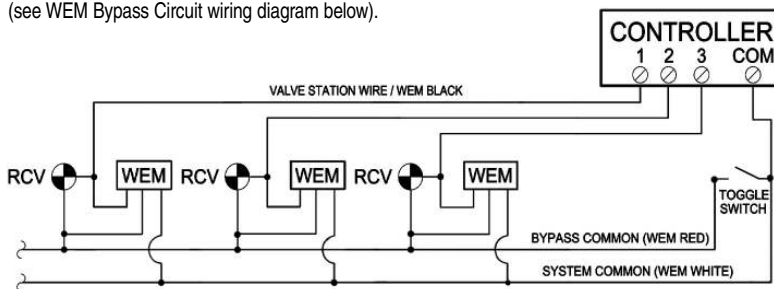

*Watermark Irrigation
No more than necessary — No Less than required*

IRROMETER CO.

Box 2424, Riverside, CA 92516
951-689-1701 • FAX 951-689-3706

techsupport@irrometer.com
www.irrometer.com